

Financial Literacy and Financial Inclusion in Rungwe, Mbeya-Tanzania

Kaula Stephen^{1*}, Gwahula Raphael², France Shayo³

¹Faculty of Business Management, Open University of Tanzania, Mbeya, Tanzania. kaula_stephen@yahoo.com

²Faculty of Business Management, Open University of Tanzania, Dar Es Salaam, Tanzania. gwahular@gmail.com

³Faculty of Business Management, Open University of Tanzania, Dar Es Salaam, Tanzania. france.shayo@gmail.com

***Corresponding author:** Kaula Stephen, 1Faculty of Business Management, Open University of Tanzania, Mbeya, Tanzania. kaula_stephen@yahoo.com

Citation: Stephen K, Raphael G, Shayo F (2022) Financial Literacy and Financial Inclusion in Rungwe, Mbeya-Tanzania. The Int Rev Eco Stu: TIRES-106.

Received Date: October 07th, 2022; **Accepted Date:** October 12th, 2022; **Published Date:** October 18th, 2022

Copyright: © 2022 Stephen K. This is an open-access article distributed under the terms of the Creative Commons attribution License, which permits unrestricted use, distribution, and reproduction in any medium, provided the original author and source are credited.

Abstract

The study aimed at assessing the effects of financial literacy on financial inclusion. The assessment came following the cases that despite of development and improvement in access to financial digital platforms but still majority of financial needy customers are financial excluded especially with developing countries where Tanzania entails. To unpack what is behind the scene, the study was conducted in Rungwe-Mbeya, Tanzania from which in most cases farmers, traders and service providers were involved. The research philosophy being positivistic while design being explanatory the fact was revealed. Moreover, from a population of 210,000, a 400 sample of respondents was deduced by employing strata-multistage sampling technique. Data from the sample frame were obtained using questionnaire. The collected data were subjected for pilot survey, cleaning, factor analysis, reliability and validity testing. Data analysis used structural equation modeling (SEM). From the analysis it was found that effective sourcing, efficient allocation of financial resources and proper projections of financial risks literacy capabilities had a positive and significant effect on sustaining financial inclusion. Thus, it is from these impressive results revealed this study recommend to financial needy customers being acquainted with necessary financial management skills for realization of financial inclusion.

Keywords: Financial literacy, financial inclusion, Rungwe-Mbeya, Tanzania.

Introduction

Financial inclusion has been the topic most of development stakeholders in the world dictate. Financial inclusion as it was reported by Ozili (2021) [1] is the situation of being accessed and used to financial services. Financial inclusion as it was portrayed by Kara, Zhou and Zhou (2021) [2] means being accessed to affordable financial services and products of the need. Financial inclusion moreover has revealed to be the cause of achievement over socio-economic transformation [3]. Either financial inclusion found to be a function of financial literacy (Mani, 2022). Actually, there are numbers of factors contributing to financial inclusion such that over financial institutions' managerial innovations in coming up with sophisticated digital systems which discard use of paper work or those

which distort the tendency of customers travel long to town or urban areas seeking for financial services. Other factors contributing to financial inclusion, presence of correspondence financial infrastructures, stable financial markets and formalization of businesses. But being the focus of this study was that even if there is such a sustained situation over enhanced financial inclusion but if user customers would not be financial literate enough to execute on financial services in order to realize expected returns, then nothing would happen.

This means that in whatever case if user customers, business firms would not be literate, then financial inclusion cannot be realized. Financial literate user source for cost-effective financial services. From the philosophy of cost minimization and maximization of outputs or profit, then financial literate

customer is able to determine the costless financial product to acquire. Normally there are two major financial sources i.e. internal sources (equity financing) and external debt financing. Thus, financial literate needy group/customer computes for the cost of each source of finance in order to determine the one with low cost of capital or simply a cheap financing mix. It is from the same where a risk-free source of finance is the one chosen in order to realize the targets (Marcelin, Egbendewe, Oloufade & Sun, 2022). The financial management skilled user customer is able to compute for expected returns i.e., the future value given the investment today called present value (Lee, Wang & Ho, 2022). This either helps to determine how much worthy expected returns given compounded interest. In the same line a financial literate user is known to cost-effective loan/credit to ask; by computing for interest (r) and principal amount to be paid today called present value given the future cash flows (FV) in a determinable time interval (n). Generally sourcing for cost effective financial product help to be acquired to affordable one.

Financial literate user customers revealed to have ability of allocating financial services efficiently for expected returns realization. This is a point of reference that even if FIs' management might be innovative to make financial services customers centered, but if users are illiterate, then the outputs or targets cannot be realized, thus financial adequacy cannot be attained [1]. Financial literate user customer optimally or efficiently allocates even little financial products a user might acquire to realize output. This is the philosophy financial institutions (FIs) use in lending money to a user customer that giving out money to financial illiterate is very risky and that is why collateral (for compensation in case it happens that a borrower fails to repay the money) is demanded during borrowing. This is the same why FIs intimidate great interest charge to consumer loans than business loans. Moreover, FIs adopt on the principle that you cannot give money to someone who cannot use it in realization of expected returns. The same concept what was said by Shen, Hu and Hueng (2018) [2] that lending money to financial illiterate user is very risky for the money learnt to be not repaid. As it was reported by

Bongomin, Munene, Ntayi and Malinga (2018) [3] the risks associated with lending to financial illiterate users include credit and default financial risks [4]. These risks are the major cause of nonperforming loans and credit losses which lead to financial inadequacy to both FIs and financial user customers [5]

Financial literacy dictates on the appropriate forecasting for the risk to occur over the investment on hand. Normally investments are subjected to risk distortions of which then if would not be projected; the expected returns on investments would not be realized and thus financial inadequacy. Risk forecasting involves identifying risks areas of exposures and finds ways to mitigate them [6]. Financial literate user customer assumes for portfolio diversification so that they do not intervene expected returns. None forecasting and un-investigation of risks is a pear hand for distortions over expected returns [7]. With distortions over cash flows, it leads into financial inadequacy, the source over financial exclusion (Mader & Duvendack, 2019). Thus, asking for collateral assumes for risk free financial environment while risk projection and mitigation assures for risk diversification.

Worldwide financial inclusion was found to be at 61% (Ozili, 2021). That means 39% was a level of financial exclusion. The 39% of financial exclusion reported by was found to be mostly with Asian and African countries, the results which are consistent with what was said by Sarma (2016) [8] over 1.5 to 2 billion of population users being financial excluded in the mentioned areas.

In Botswana only 42% of population users was financial included which then was with urban and town centers financial user customers [9]. The findings by Kgangyame (2020) [10] in Botswana resembled as that by Kaula (2021) who conducted the study on determinants of financial inclusion for socio-economic transformation in Mbeya-Tanzania. From this study it was revealed that despite of population user customers in urban and town areas being easily accessed to financial infrastructures and therefore services, but still they were found acutely excluded from which only 22% of population was found to be financial

included. This is equal to 78% of financial user customers being financial excluded from the research area.

The background reviews above have pointed out the level of financial inclusion to different categories of customers and at different research area but none of the review has said on why urban and cities population users found to be easily accessed to financial services and products but still they are absolutely financial excluded. This was a knowledge gap uncovered by this study therefore from which it has revealed that financial inclusion is not a function of only over accessible financial infrastructures but integration and holistic factors where financial literacy details. To reveal this knowledge gap three research objectives were formulated including, to assess the effects of financing financial skills on financial inclusion; examine the effects of efficient allocation of financial resources sourced on financial inclusion; and to analyze the effects of proper risks projection on financial inclusion.

Literature Review

Theory: The study was guided by business development model found by Prabha and Bhist (2013) [11]. The model proposes that for financial users efficiently act on acquired financial products in order to maximize the returns, and thus intellectual development is unavoidable. The model proposes on the importance of developing both internal and external customers. The internal customers were described as financial institutions' staff in which through training their efficiency and productivity increases. The external customers were the user customers demanding for financial services and products for their investments or businesses. It was moreover revealed that financial literate user customer plan for better or simply budget for the financial resources acquired (Kodongo, 2018) [12]. Moreover, Shen Hu and Hueng (2018) [13] stipulated that financial literate customer offer for appropriate allocation of finance and able to forecast risks only to ensure that the expected returns is realized. It was therefore suggested that the government has to intrude the courses regarding financial management and control at a grass root i.e., primary school level. This is expected to equip the young creatures with financial

management skills while they are still immature and therefore creating with them the behavior of financial discipline. Furthermore, [14] proposed on establishment of financial credit counseling centers just in rural areas for the termed disadvantageous remote rural population users get accessed to financial trainings. This is from the fact that financial inclusion cannot be achieved by financial institutions' management being innovative or through presence of supporting financial infrastructures or through businesses formalization only but in togetherness with user-customers being financial literate.

Empirical studies: According to Magalhaes-Timotio, Barbosa and Ferreira (2022) [15] in Brazil it was found that financial literate users were in better position to choose the suitable financial products which indeed fulfill their need as compared to illiterate ones. This showed the extent to which financial literate users were well equipped with skills regarding capital structure to be able to select the affordable financial product and of the desire. Apart from being accessible to affordable financial services, financing capability revealed to help increase access to financial services and products. This is either a financial packaging of its kind in which different types of financial needy customers are accessed to their own financial products. The study by Magalhaes-Timotio, Barbosa and Ferreira (2022) [16] was reflexive and anti-positivistic philosophical investigation from which snow ball sampling technique was used to derive to 77 respondents from a total population of 1200 unit of inquiry. The focus group of the study by Magalhaes-Timotio, Barbosa and Ferreira (2022) [17] were the micro-enterprises firms involved in trading and manufacturing business activities.

In South Africa Dossou, Aoudji, Houessou and Kaki (2020) revealed that appropriate allocation of financial resources increases acquisition of agri-implements by 21%. It was more over revealed that the gross agricultural produce increased by average of 35% while revenue rose to 10% from 0.2% with small holders' farmers. It was furthermore found that productive efficiency lead into realization of expected returns and therefore financial adequacy. The study by Dossou, Aoudji, Houessou and Kaki (2020) [18]

was descriptive while simple percentages were used to present data.

Risk portfolio diversification found to contribute to financial inclusion [19]. It was moreover realized that being able to compute for risk diversification helped production firms become assured with the expected returns hence financial adequacy. The study by Ndanshau and Njau (2021) [20] was carried out in Dar Es Salaam from which causal-effect research design was used.

The studies above have revealed how efficient execution of financial resources lead into financial inclusion but none has said on that attaining to financial inclusion is integration and holistic thing. That was this study called for intrusion of the variable financial literacy while the study being conducted in Rungwe-Mbeya, Tanzania from which farmers were the key informants. Moreover, while the studies above were descriptive and some exploratory, this one under discussion was explanatory. Also, while other studies used qualitative data analysis methods, this study used a quantitative, structural equation modeling technique.

Methodology

The study was conducted in Rungwe district found in Mbeya region. This area was chosen exemplifying other areas in Tanzania and the world at large where financial user customers are not efficient enough in allocating the financial products acquired to realize financial inclusion in return [21]. To reveal what was behind the dilemma, this study used to explanatory research design while the philosophy being positivism. From a total population of 210,000, the sample n=400 was obtained. Deduction of sample, n stated employed a Cochran formula given as, $n = \frac{N}{1 + N(\alpha)^2}$ where N = population size=210,000; n = sample size=400; α =margin of error=0.05. Moreover, the study used the strata-multistage sampling technique. The main strata considered during sampling process were location, size and economic activities financial user customers (firms) were engaged in. In case of location rural and urban users were involved as it was with size were large- and small-scale firms; and the economic activities from which customers engaged in farming, trading and service provision were involved (Refer Table 1).

Table 1: Sample deduction.

Location			Size			Economic activities		
Stratum	Population	Sample	Stratum	Population	Sample	Stratum	Population	Sample
Rural	58,000	61	SMEs	52,000	51	Farmers	41,000	91
Town (Tukuyu)	2,000	56	LSF	8,000	41	Traders	28,000	52
						Service providers	21,000	48
TOTAL	60,000	117		60,000	92		90,000	191
n=400								
N=210,000								

From the sample frame derived, data were collected using questionnaire. Later the questionnaire was piloted. The pilot study used 25 responses being within the acceptable range of 10-30 recommended by Machin, Campbell and Tan (2018) [22]. The pilot survey was conducted to ensure for construct validity and reliability. Reliability testing gave the results of cronbachs' alpha (α) = 0.76 for optimal sourcing of cost-effective source of finance; 0.79 for efficient allocation of sourced financial products; 0.82 for proper risk projection and diversification; and 0.80 for financial inclusion (See

Table 3). At the end of pilot survey, exploratory factor analysis was conducted to check for belongings of variables.

The collected data were processed before actual data analysis. Data processing involved data cleaning, capturing missing values, removing outliers and testing for normality. From a dataset, 8 sets equal to 3% of missing values were highlighted and deleted by employing pair-wise data deletion method. Using MD computation, 51 extreme data were removed. Mahalanobis distance (MD) computation

retained 250 responses which were subjected into normality testing. Furthermore, using absolute coefficient of skewenes -/+2 was a normal distribution of results expected to be. Actual data analysis used SEM where multi colinearity, linearity and homoscedastic testing were undertaken. The analysis was guided by the following structural equation: -
 $FI = \beta_0 + \beta_1 \sum F + \beta_2 \sum AL + \beta_3 \sum RF + e$

where FI = Financial inclusion; F=Financing capabilities; AL= Efficient allocation of financial resources; RF = financial risk projection/mitigation; e= error term.

Findings and Discussion

The Respondents' Profile

This was a descriptive analysis of respondents' characteristic. Respondents' profile stipulated on gender, age, distribution, financial training, and concentration of financial trainings as they were found to be related to the study underhand.

Table 2: Respondent's characteristics.

Variables	n	%
Gender		
Male	60	24
Female	20	8
Age		
<16yrs	5	2
16-35yrs	160	64
36-45yrs	50	20
>45yrs	35	14
Financial trainings		
Accessible	85	34
Not accessible	165	66
Concentration of financial trainings		
Urban areas	125	50
Town areas	105	42
Rural areas	20	8

Gender

With 60 (24%) for males found to be equipped with financial management skills against 20 (8%) of females involved indicate the fact in which population users from the area were largely financial excluded. The non-impressive results resemble as that of World Bank (2018) [23] on the level of financial exclusion in Tanzania by 71%. Moreover, the results over 32% only of financial needy customers being financial included equal to 68% of the needy group financially excluded. These results were consistent with those of FSDT (2017) [24] in which 81% of adult population users who were found to be financial excluded; 26.5% of agro processors and 16% of agribusiness firms in Tanzania being financial included. Either, this is to say, the little 32% of financial inclusion was for population users found in Tukuyu town where financial consultancies such as trainings were accessible.

Age

With 160 (64%) for respondents in the age range of 16-35 years indicated that respondents involved was adequate and reliable to make a sample frame of adult productive labor forces. The productivity of respondents expected from this group was from the fact that it was in the consistent age interval of labor force not expected to be dependable and thus the issue of how optimally finance is to be allocated o realize the expected returns was to be built with the group. Moreover, productivity was centered at 50(20%) of respondents surveyed having age of 36-45 years which was still satisfactory labor force to execute to financial adequacy. The 5(2%) for surveyed respondent age range being for those with less than 16years, as it was the same for 24% (35) with age level>45 years, dependent group in the society. The population users<16 years were young and >45 years were elders and therefore none productive.

Financial trainings

With 165 respondents equals to 66% of responses regarding the found non-accessible financial trainings against 85 (34%) of its accessibility. 34% equals to 56 rural financial users found in Tukumyu town plus less than 52 traders a less than 48 service providers involved in this study. The great 66% of non-accessibility over financial trainings indicated trainings to be not much invested by financial institutions. Either this level of inaccessibility of financial services revealed was due to self-exclusion showing financial customers not able or not bothers to search for financial services due to financial deficiencies. This therefore call for financial institutions to invest on financial programs diversification such that over financial trainings. This is to be done in order to equip or update financial users with financial management skills for them realize financial adequacy thus financial inclusion.

Concentration of financial trainings

Given 50% (125) of trainings concentration level being conducted in urban areas equated to 42% (105) of trainings found to be concentrated in towns (cities) showed the most of training to be conducted in urban and town areas. Thus, from the research area the areas such over Masukulu, Bulyaga, Ibungila were remote and therefore not accessed by financial services. That means the population users in the mentioned areas were far from Tukumyu town, thus they were disadvantageous group. This group most of small holders' farmers equals to 20 (8%) and much of small-scale firms in informal sector. This study has been a platform and it is a reminder for financial institutions to establish or locate the financial credit counseling centers in most remote rural areas some mentioned above.

Model formulation and Validation

This section helped to consider if the proposed conceptual framework was indeed consistent with actual data. This is because at the beginning, the conceptual framework was developed without data; it is now not clear if the constructs are aligned with their underlined measure.

To ensure constructs are aligned with their underlined measure, factor analysis of both exploratory factor analysis and confirmatory factor analysis was used as described below: -

First exploratory factor analysis with varimax rotation was conducted to assess the underlying structure for twenty-five (25) items of the conceptual framework. In selecting factors to retain four criteria were adopted namely Eigen values, scree test (i.e scree plot), theoretical assumption and factors that have at least three items (Price, 2017) [25] recommended the use of a combination of criteria to help to offset the weakness of using one criterion.

Given this situation four factors were extracted based on those four criteria which explain 77.27% of the cumulative variance. The four factors had Eigen values above >1. In a screen test, all factors above the cut-off point were retained and those below the break out /off point were dropped. Finally, all retained factors had at least three indicators. This means that all retained factors had met the recommendation made by Price (2017) [26].

After discovering that the four factors have met the criteria and now are qualified to be retained, further analysis of indicator variables was done in order to see if this indicator really fits their underlying factor. The following criteria recommended by Yongo and Pearce (2013) [26] were adopted for retaining/dropping an item/indicator as follows: -

First all items loaded into more than one factor were retained and those loaded into more than one factor were dropped. Second if more than two items loaded in one factor, all items were retained and if less than three items one factors were dropped. Third, all items with KMO, p-value greater than 0.5 were retained and those with less than 0.5 were dropped. Fourth, loading less than 0.5 or above 0.8 was dropped. As far as this part is concerned, the three to five items in each factor were retained indicating to adequately fit the model (See Table 3).

Table 3: Rotated Component Matrix.

Constructs	Indicators	F	AL	RF	FI
F	Sourcing	0.808			
	C/B	0.804			
	SAFP	0.777			
	AC/USA	0.742			
AL	P/E		0.817		
	E/R		0.777		
	R/D		0.760		
	R/C		0.746		
RF	R/R			0.801	
	R/S			0.742	
	R/T			0.677	
	Proactiveness			0.720	
FI	AC				0.698
	AD				0.745
	AF				0.590
Eigen values		6.407	3.421	2.415	1.972
% Of variance		19.984	19.806	19.592	18.886

After exploratory factor analysis, the next step was to perform confirmatory factor analysis to account for measurement error which was not addressed in exploratory factor analysis as described in detail below: -

To carry out confirmatory factor analysis, the measurement model was developed based on the factors from exploratory model to test for measurement error. The following criteria were used to guide the model refinement process to achieve a better model fit as recommended by Barbra (2019) [27] who asserts that standardized regression weights (S.R.W) values should be above 0.5, the value of GFI, AGFI and

CFI>0.9 and RMSEA<0.08. Therefore to enhance the model fitness, an item with modification indices that reveal high covariance between measurement errors accompanied by high regression weights between these construct errors were dropped. Running of CFA using AMOS 25 revealed that a GFI =0.942; AGFI =0.92; CFI 0.971>0.95 accepted; and RMSEA =0.024<0.05 perfect. All items retained had standardized regression weights (S.R.W) values cut off of 0.5 or greater than the accepted fit, hence falling within the accepted threshold level. This means that the selected observed variable used fit the model as described in Figure 2.

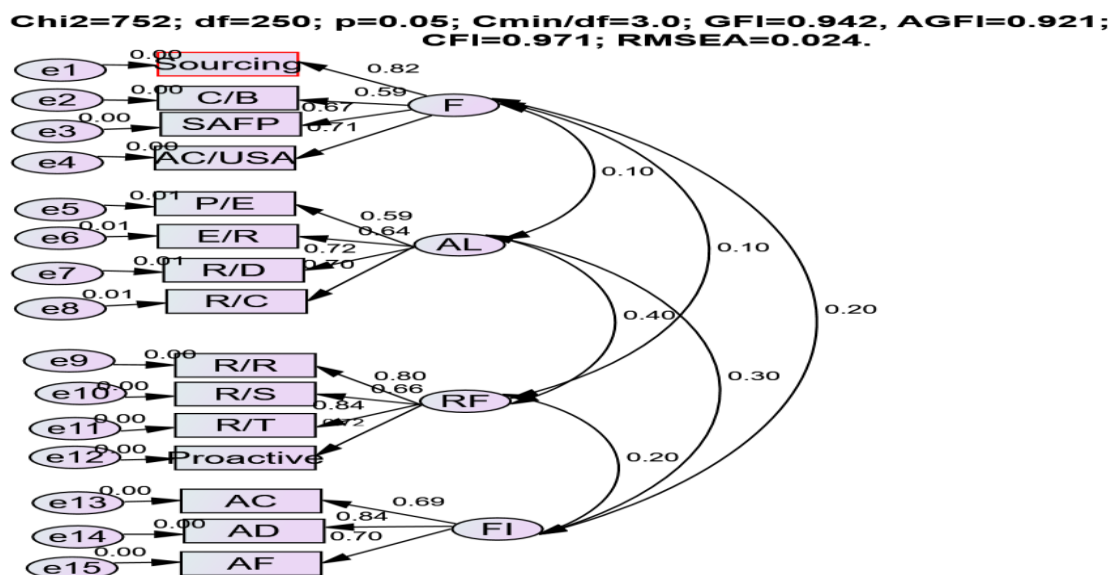

KEY NOTE

F=Financing; **C/B**= cost benefit analysis; **SAFP**= sourcing affordable financial products; **AC/USA**=accessibility and usability of financial services; **AL**= efficient allocation of financial resources; **P/E** = productive efficiency; **E/R**=expected returns; **R/D**= risk diversification; **R/C** =assurance of credit repayment; **RF**=Risk forecasting; **R/R**=risk recovery; **R/S**= risk sharing; **R/T**= risk transferring; **FI**= financial inclusion; **AC**= financial accessibility; **AD**=financial adequacy; **AF**= affordable financial services.

Figure 2: Measurement Model

Having established the model fit and all hypothesis of the relationship between observed (indicators) and unobserved variables (latent constructs) have agreed in the measurement model, the next step was to move to a structural model to test the existence of relationship in the model. The basic structural model which hypothesized the relationship between financing, efficient allocation of resources, risk projection on financial inclusion was analyzed. The results of the analysis of the basic structural model using AMOS version 25 were as shown in Figure 3.

Reliability and Validity testing

Reliability was evaluated in terms of cronbachs' alpha (α) described in Table 1. The cronbachs' alpha in Table 4 ranges

from 0.804 to 0.859 which were all recommended value of 0.7, suggesting adequate internal consistency [28].

Convergent validity and discriminant validity was assessed based on the results of the measurement model as described in Table 4. Convergent validity was evaluated in terms of average variance extracted (AVE) which explained the variance that was measured by the construct in relation to the measurement error. Shaffer, De- Geest and Li (2016) [29] argued that convergent validity requires an AVE of not less than 0.5. Results in Table 4 show that all AVE were above the recommended value of 0.5 (ranging from 0.721 to 0.889) thus demonstrating adequate convergent validity.

On the other hand, divergent validity was evaluated by comparing the AVE of each individual construct with the shared variances between this individual construct and all of the other constructs. A higher AVE than shared variances for an individual construct suggest divergent validity (Straub, Boudreau & Gefen, 2004) [30]. A comparison of all the correlations and square roots of the AVEs on the diagonal in Table 4 indicated satisfactory divergent validity.

Table 4: Reliability and Construct Validity testing results (N=250).

Constructs	Cronbachs' alpha(α)	AVE	MSV	Max R(H)	F	AL	RF	FI
F	0.846	0.843	0.121	0.952	0.940			
AL	0.804	0.723	0.054	0.874	0.201	0.842		
RF	0.857	0.886	0.123	1.014	0.241	0.254	0.961	
FI	0.835	0.793	0.134	0.862	0.301	0.132	0.125	0.893

Structural Equation Modeling

Financial literacy and financial inclusion

With this heading the study aimed at determining the strength of the relationship between financial literacy and financial inclusion. In this hypothesis testing the independent variables defining financial literacy included financing, efficient allocation and risks forecasting while dependent variable was financial inclusion. The testing used the standardized regression weights in which the acceptable range was ≥ 0.5 at p -value <0.05 [30]. The multiple regression relationship was modeled by employing fit index matrices.

Financing and financial inclusion

In here the study was motivated to reveal the effect of financing literacy on financial inclusion. It was assumed that financing positively related to financial inclusion. The results $S.R.W = 0.7$ at $p=0.00$ (See Table 5) indicated that financing had a positive and insignificant influence on financial inclusion. This is a proven fact that financing being a capitalization process then to be achieved to affordable financial products, it helps sustain financial inclusion.

A financial literate user looks for cheap financial product /service of the need (Kartwinata, Fakhri, Pradana, Hanifan & Akbar, 2021) [31]. Normally there are two major sources of finance called financing mix i.e. equity and debt financing

[32]. With this financial needy customer computes for the cost of capital or cost of financing. Thus the revealed cheap financial product is the one which is acquired. It is with financing in which a financial literate user does compare the cost of capital of different sources and expected returns called cost benefit analysis. With this either the source of finance or financial product with viable marginal returns (benefit) is the one chosen for financial adequacy and sustainability. Simply a financial literate user chooses financial credit with less covenants and low interest rate for reasonably present value (PV) of the borrowed amount. Moreover, with financing, the source of finance reaches the weighted average cost of capital which is the minimum cost to be incurred in financing mix. Apart from accessing to affordable financial products; financing financial literacy found to increase accessibility and usability of financial services/products of the need. This fact differs from what was reported by Financial Sector Deepening Trust (2017) [33] over the study regarding assessment of the level of financial inclusion with farmers in Tanzania. From this study it was found that 84% were able to add and subtract but 54% were not able to multiply and divide showing how extensive the problem of financial illiteracy was with the unit of inquiry.

Financial allocation efficiency and financial inclusion

In here the study aimed at examining the effects of efficient allocation of financial resources acquired or sourced in realization of financial inclusion. Thus with $S.R.W = 0.80 > 0.5$ at $p = 0.01 < 0.05$ indicated the feasibility of the results i.e. allocative efficient revealed to be positive and significant determinant of financial inclusion. This was a proven fact that when scarce resources are optimally utilized, financial adequacy becomes enacted. It is with appropriate utilization of financial resources say credits, savings what ensures expected returns realized. Assurance over the results expected to be obtained is what give trust to financial institutions continue injecting money to the needy group. This in return helps to attain financial capital accumulation. Moreover, assurances over the expected returns implicate the capability or possibility of the money lent to be repaid [34]. Thus, assurance of money borrowed to be repaid on

time is what cultivates for financial, credit and default risks being diversified. Therefore, it is because of being not sure whether the money learnt would be repaid or simply because of financial institutions operating on non-trusted financial environment for the money borrowed to be not repaid [35]. It is because of fear of incurring non-performing loans and credit losses due to inefficient allocation of credits provided to financial illiterate what makes financial institutions not trust them for the money to be given out. It was with positive and significant results i.e. $S.R.W = 0.80$ at $p < 0.05$ what this study insist on financial users to be acquainted with financial management skills for them efficiently allocate resources to the highly or greater boom up project. It is therefore due to financial ignorance what makes financial credits become risky. This either recommend that instead of financial needy customers thinking of asking for credits, then they should invest on other financial services such as savings and insurances. Because with financial illiterate users, the returns on investment cannot be propounded, then that is why they refuse to lend money to these groups of financial needy customers. If the money is learnt then lending is subjected to very high rate associated with non-feanate repayment time and more other restrictions. Moreover, it is by the reason that most businesses of financial illiterate users can not realize returns high interest rate is because there is no assurance for the money lent to be repaid and therefore the principle fast and earlier debt collection is used. Another principle financial institutions are used to before executing borrowings is that money cannot be lent to a person who cannot use it [36] or simply misallocate and end up with returns not being realized and that is when 5Cs [37], CAMPARI [38] or PARSER [39] models come into application.

Risk projection and financial inclusion

With this subtitle, the study aimed at determining the strength of effects of risk projection on financial inclusion. Risk projection is the plan that a firm has to execute to avoid distortions due to political, technological, economic, environmental and social financial environment changes. From the field indeed given $S.R. W = 0.79$ at $p = 0.00$. This

showed that effective risk projection and financial inclusion was two variables positively but insignificantly related. This was a good measurement results from the fact that risk projections create a sought of risk diversification called risk recovery, transferring and sharing which reduces destructions (Lee, Wang & Ho, 2022) [40]. Risk projection is a proactive juncture which is motivated to combat them before their actual acutance [41]. Risk projection is a preventive measure of the distortions due to changes in financial environment. The positive results over standardized regression weights were therefore focused at systematic risks and not systemic ones. Systematic risks include inflation (i), exchange rate (FX) movement, interest rate movement (r) [42].

It is with the positive results regarding the standardized regression coefficients what assures risk projection to be an important practice which assures a business firm realizes

expected returns important for sustaining financial adequacy [43]. It is therefore through risk projections what calls for the firms insure their businesses. Thus, insurance help to diversify systematic risks. Asking for or entering insurance contract such that over fire outbreak, thieves and burglary play role in protecting a business from such distortions. Asking for crop insurance help to protect crop from effects over climatic changes such as flood, heavy rainfall, drought [44]. Asking for health insurance play role in insurance over productive efficiency of a laborer. As it was said by Matsebula, and Yu (2020) [45] it is a true-fact that insurance function as camouflage or simply compensation over loss or debt a firm might be facing for the business not read marginal returns. To sum up is that risk projections function in increasing financial sustainability [46]. It was furthermore reported that risk projections help to protect business from distortions which is therefore a prior usuation for financial capital adequacy [47].

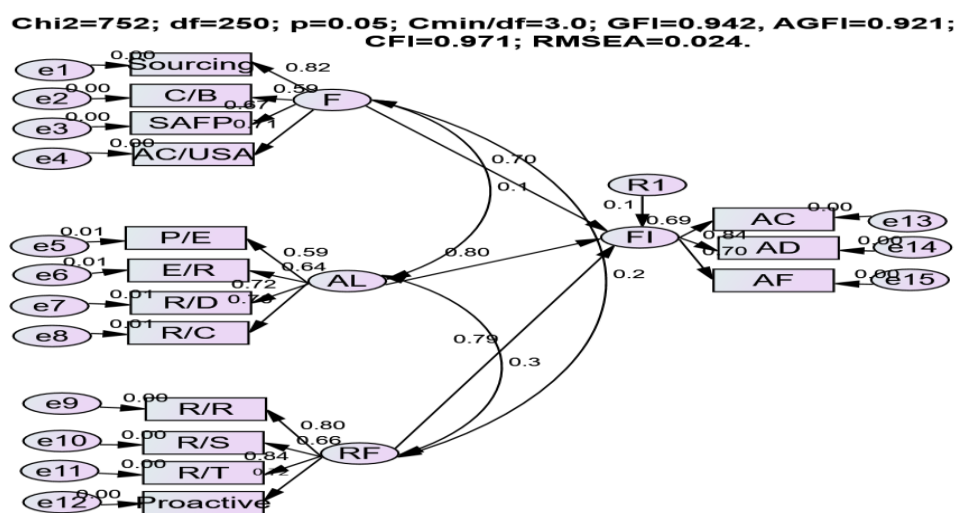

Figure 3: Structural Model

Hypothesis Testing

In hypothesis testing, the study aimed at determining the strength of relationship between the variable financial literacy and financial inclusion. The financial literacy was defined by factors financing skills (F); allocative efficiency (AL) and appropriate risk projection (RF). In determination of the strength of relationship between variables the study

used standardized path coefficient, δ , critical ratio (C.R) at a given significance level. The recommended level for the relationship to be revealed positive and significant is when $\delta > 0.2$; $C.R > 1.96$ and $p < 0.05$ [48]. The results of strengths of relationship between variables was extracted and presented as shown in Table 5 below.

Table 5: Hypothesis testing results.

Hypothesis	Relationships	Estimate	Error	C.R	p	Path coe.	Remarks
H _{1a}	FI<-----F	1.00	0.10	2.00	0.01	0.42	Reject
H _{2a}	FI<-----AL	0.94	0.08	1.98	0.03	0.25	Reject
H _{3a}	FI<-----RF	0.76	0.02	1.97	0.00	0.50	Reject

Under hypothesis 1(H_{1a}) it was expected that financing financial literacy has negative and insignificant determination of financial inclusion. Thus, with $\delta=0.42$ at C.R =2.00; p=0.01, the alternative hypothesis is rejected in favor of null hypothesis. This either means that, it is by being financial literate in financing i.e., choosing for cost effective source of finance what foster for access to affordable and the needy financial products/services. This therefore indicated that for financial user customer being able to compute for the cost of capital and select the cost-effective source has a positive and significant determination of financial inclusion.

Under hypothesis 2 (H_{2a}) it was assumed that allocative efficiency financial literacy has a negative and insignificant determination on financial inclusion. Thus, with $\delta =0.25$ at C. R=1.98 where p=0.03, this indicated that efficient allocation of acquired financial resources positively and significantly gave rise to financial inclusion. This either implied that non misuse of financial resources helps to attain expected returns. This either reduces late payment of the borrowings. This moreover helps to control or overcome the problem of default risk, credit and currency risks which are the major cause of non-performing loans and credit losses [26]. That means productive efficiency lead into performing loans and credit gain for financial institutions become financial included and therefore continue providing more credits.

Under hypothesis 3 (H_{3a}): it was expected that proper risk planning had negative and non-significant effect on financial inclusion. Thus, with $\delta=0.50$ at C.R =1.97, p=0.00 showed the alternative hypothesis results to be rejected in favor of null hypothesis. The fact in here is that proper planning for risk help to over helm the distortions that could disturb the expected outcome. Risk planning implies risk portfolio diversification that play role to mimic the deviations over the expected returns, thus sustaining financial inclusion.

Conclusion and Recommendations

Financial literacy found to be significant determinant of financial inclusion. By adopting integration and holistic model is that financial service providers (financial institutions) might be innovative in coming with digital systems for fostering customer service centrality but if financial user customer is not financial literate enough, financial inclusion cannot be realized. Financial literacy as refers to this study included the following variables, financing capability; executing efficiency in financial allocation and being able to forecast and mitigate financial risks. All these variables found to have positive and significant determination over financial inclusion. It is from those blessing results; thus, the study recommends the following: -

Financial needy customers should be acquainted with necessary financial management skills for the realization of expected returns and thus financial adequacy. Financial user customers should acquire appropriate trainings for them efficiently allocate the acquired financial resources. On the other hand, financial institutions should invest on training and if not, enough the financial credit counseling centers are to be installed just near homes of customers. Also the government through a central bank should be strongly enforcing financial policies such that over financial inclusion framework of 2013.

References

1. Abor, J.Y., Amidu, M., & Issahaku, H. (2018). Mobile telephony, financial inclusion and inclusive growth. *Journal of African Business*, 19(3), 430-453.
2. Backman-Kartal, H. (2021). Formalizing the Informal Sector, is it Desirable for Everyone?: South African Informal Operators, Bankers, Researchers and Policymakers Elaborating on Their Understanding of Formalization, and the Way Towards Financial Inclusion.
3. Bire, A.R., Sauw, H.M., & Maria, M. (2019). The effect of financial literacy towards financial inclusion through financial training. *International journal of social sciences and humanities*, 3(1), 186-192.

4. Bongomin, G.O.C, Munene, J.C., Ntayi, J.M., & Malinga, C.A. (2018). Nexus between financial literacy and financial inclusion: Examining the moderating role of cognition from a developing country perspective. *International Journal of Bank Marketing*.
5. Boumparis, P., Milas, C., & Panagiotidis, T. (2019). Non-performing loans and sovereign credit ratings. *International Review of Financial Analysis*, 64, 301-314.
6. Chan, S. (2021). Financial repression and financial risk: the case of China. *Post- Communist Economies*, 33(1): 119-132.
7. Dossou, S.A., Aoudji, A.K., Houessou, A.M., & Kaki, R.S. (2020). Microfinance services for small holder farmers: an assessment from rice farmers' expectations in Central Benin. *Agricultural and food economic*, 8(1), 1-15.
8. Fang, D., & Zhang, X. (2021). The positive effect of digital financial inclusion on agricultural supply chain during the COVID-19 pandemic: Evidence from china. *Journal of Theoretical and Applied Electronic Commerce research*, 16(7), 3202-3217.
9. Feghali, K., Mora, N., & Nassif, P. (2021). Financial inclusion, bank market structure, and financial stability: International evidence. *The Quarterly Review of Economics and Finance*, 80, 236-257.
10. Financial Sector Deepening Trust FSDT, 2017). The level of financial inclusion by adult population users in Tanzania.
11. Fin-Scope (2017). Insights that drive Innovation. The National Financial Inclusion. FSDT-Dar ES Salaam-Tanzania.
12. Grohmann, A., Kluhns, T., & Menkhoff, L. (2018). Does financial literacy improve financial inclusion? Cross country evidence. *World Development*, 111, 84-96.
13. Gutierrez-Romero, R., & Ahamed, M. (2021). COVID-19 response needs to broaden financial inclusion to curb the rise in poverty. *World Development*, 138, 105229.
14. Heppner, A., Pawar, A., Kivi, D., & Mago, V. (2019). Automating articulation: Applying natural language processing to post-secondary credit transfer. *IEEE Access* 7 (2019): 48295-48306.
15. Huang, H., Chau, K.Y., Iqbal, W., & Fatima, A., (2022). Assessing the role of financing in sustainable business environment. *Environmental Science and Pollution Research*, 29 (5), 7889-7906.
16. Kadongo, O. (2018). Financial regulations, financial literacy, and financial inclusion. Insights from Kenya. *Emerging Markets Finance and Trade*, 54(12), 2851-2873.
17. Kaplan, D. (2000). *Structural Equation Modeling: Foundations and Extensions*. Sag. Newbury Park, CA.
18. Kara, A., Zhou, H., & Zhou, Y. (2021). Achieving the United Nations' sustainable development goals through financial inclusion: A systematic literature review of access to finance across the globe. *International Review of Financial Analysis*, 77, 101833.
19. Karl, L., Wuensch (2012). A Brief Introduction to Reliability, Validity and Scaling. Reliability-Validity-Scaling.docx. URL: <http://www.core.ecu.edu./psyc/.../Reliability-Validity-Scaling.docx>.
20. Kartawinata, B, R., Fakhri, M., Pradana, M., Hanifan, N.F., & Akbar, A. (2021). The role of financial self efficacy: mediating effects of financial literacy and financial inclusion of students in West Java, Indonesia. *Journal of Management Information and Decision Sciences*, 24(7), 1-9.
21. Kgangyame, L. (2020). Effects of financial inclusion on poverty reduction and income inequality in Botswana.
22. Kline, R.B. (2012). Assumptions in Structural Equation Modeling.
23. Le, T.H., A.T., & Taghizadeh-Hesary, F. (2019). Financial inclusion and its impact on financial efficiency and sustainability: Empirical evidence from Asia. *Borsa Istanbul Review*, 19(4), 310-322.
24. Lee, C.C., Wang, C. W., & Ho, S.J. (2022). Financial aid and financial inclusion: Does risk uncertainty matter? *Pacific-Basin Finance Journal*, 71, 101700.
25. Machin, D., Campbell, M.J., Tan, S.B, Tan, S.H. (2018). Sample sizes for Clinical, Laboratory and Epidemiology studies, Fourth Edition: John Wiley and Sons. Hoboken, New Jersey.
26. Mader, P., & Duvendack, M. (2019). Impact of financial inclusion in low and middle-income countries: A systematic review of reviews.
27. Magalhaes-Timotio, J.G., Barbosa, F.V., & Ferreira, B.P. (2022). Constructing a composite financial inclusion index for Brazil. *Revista Gestao & Tecnologia*, 22(1). 168-192.
28. Mani, M. (2022). Financial inclusion Through Financial Literacy: Evidence, Policies and Practices. *International Journal of Social Ecology and Sustainable Development (IJSESD)*, 13(1), 1-12.
29. Marcel, I., Egbendewe, A.Y., Oloufadi, D.K, & Sun, W. (2022). Financial inclusion, bank ownership, and economy performance: Evidence from developing countries. *Finance Research Letters*, 46, 102322.
30. Martinez, C.H., Hidalgo, X.P., & Tuesta, D. (2013). Demand factors that influence financial inclusion in Mexico: analysis of the barriers based on ENIF survey. BBVA Bank, BBVA Research Working Paper, 1-19.
31. Matsebula, V., & Yu, D. (2020). An analysis of financial inclusion in South Africa. *African Review of Economics and Finance*, 12(1), 171-202.
32. Ndanshau, M.O., & Njau, F.E. (2021). Empirical investigation into demand-side determinants of financial inclusion in Tanzania. *African Journal of Economic Review*, 9(1), 172-190.
33. Ol, K., SA, M., II, S., RR, S., AS, T., & NG, B. (2021). Improving the methodological approach to identifying financial risks in the context of macroeconomic instability of the economy.
34. Omar, M.A., & Inaba, K. (2020). Does financial inclusion reduce poverty and income inequality in developing countries? A panel data analysis. *Journal of economic structures* 9(1), 1-25.
35. Ozili, P.K. (2021). Financial inclusion research around the World: A review. *In Forum for social economics* (VI, 50, No 4, pp.457-479). Routledge.

36. Price, L.R. (2017). *Psychometric methods: Theory into practice*. New York, NY: Guilford Press.
37. Radivojevic, N., Cvijanovic, D., Sekulic, D., Pavlovic, D., Jovic, S., & Maksimovic, G. (2019). Econometric model of non-performing loans determinants. *Physica A: Statistical Mechanics and its Applications*, 520, 481-488.
38. Renzhi, N., & Baek, Y.J. (2020). Can financial inclusion be an effective mitigation measure evidence from panel data analysis of the environmental Kuznets curve. *Finance Research Letters*, 37, 101725.
39. Sahela, K.Z., Susanti, R., & Adjie, A.R. (2021). The influence of government dimension on financial education and empowerment of micro-small and medium-sized enterprises in Indonesia. *The Journal of Asian Finance, Economics and Business*, 8(3), 637-643.
40. Sarma, M. (2016). Measuring financial inclusion for Asian economies. *Financial Inclusion in Asia* (pp.3-34). Palgrave Macmillan, London.
41. Semaye, A. (2018). Assessment of 5Cs credit appraisal tools and the level of Non performing loans and advances-in the case of NIB International Bank SC (Doctoral dissertation, St. Marys University).
42. Shaffer, J.A., de Geest, D., & Li, A. (2016). Tackling the problem of construct proliferation: *A guide to assessing the discriminant validity of conceptually related constructs Organizational Research Methods*, 19 (1), 80-110.
43. Shen, Y., Hu, W., & Hueng, C.J. (2018). The effects of financial literacy, digital financial product usage and internet usage on financial inclusion in China. *MATEC Web of Conferences* (Vol. 228, p.05012). EDP Sciences.
44. Shen, Y., Hu, W., & Hueng, C.J. (2018). The effects of financial literacy, digital financial literacy, digital financial product usage and internet usage on financial inclusion in China. *In MATEC Web of Conferences* (Vol.228, p.05012). EDP Sciences.
45. Straub, D., Boudreau, M. & Gefen, D. (2004). Validation guidelines for IS positivist research, *Communications of the Association for Information Systems* 13(24), 380-427.
46. Vo, D. H., Nguyen, N.T., & Van, L.T.H. (2021). Financial inclusion and stability in the Asian region using bank-level data. *Borsa Istanbul Review* 21, no.1 (2021): 36-43.
47. World Bank (2018). The level of financial inclusion in Tanzania. Dar Es Salaam-Tanzania.
48. Zhilina, N.N., Magdeeva, M.R., Ignatev, V.G., Nurtdinov, I.I., & Gusarova, L.V. (2021). A comparative analysis of the methods used to assess borrower creditworthiness. *In Frontier Information Technology and Systems Research in Cooperative Economics* (pp.991-999). Springer, Cham.